

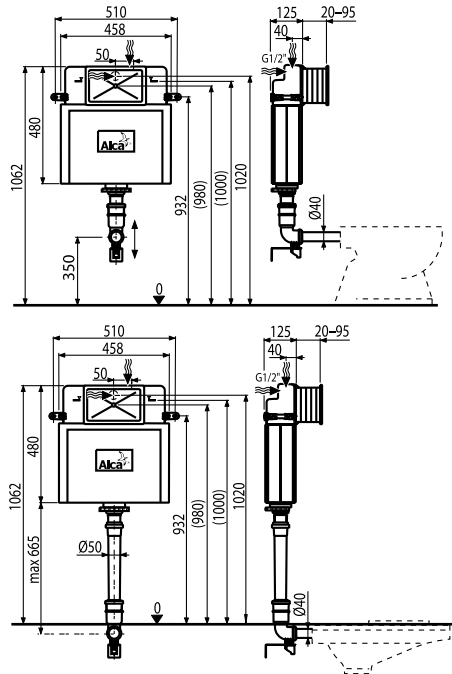

A112

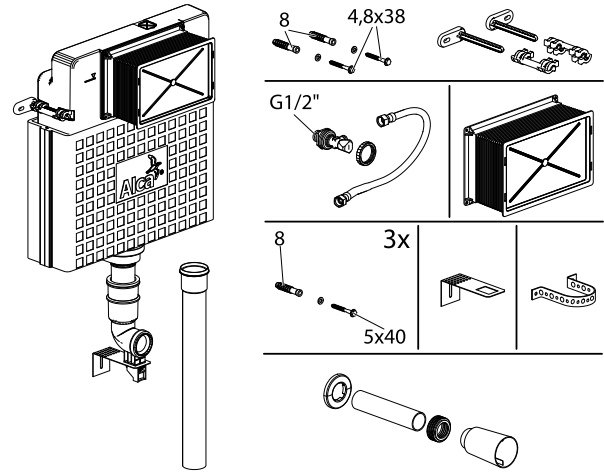

[mm]



1

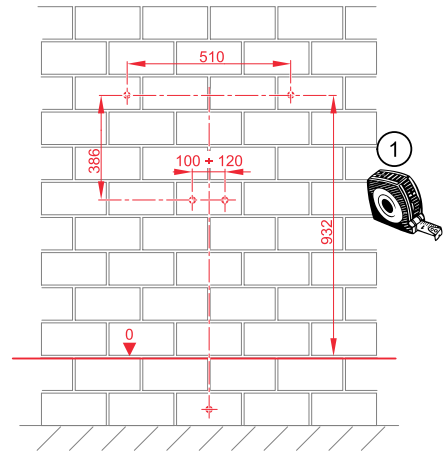
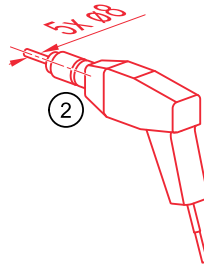
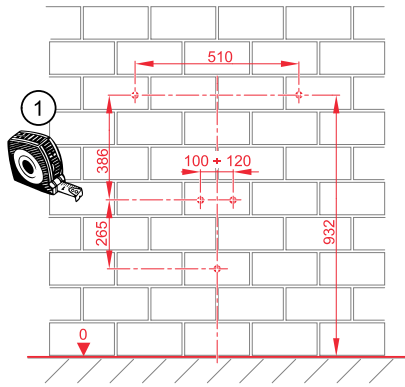

2

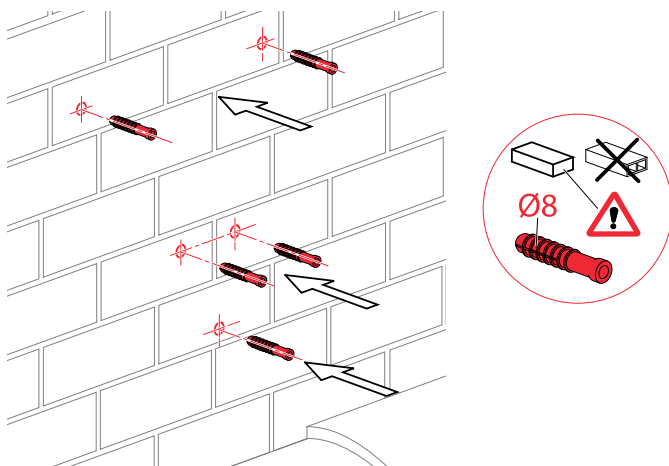

3

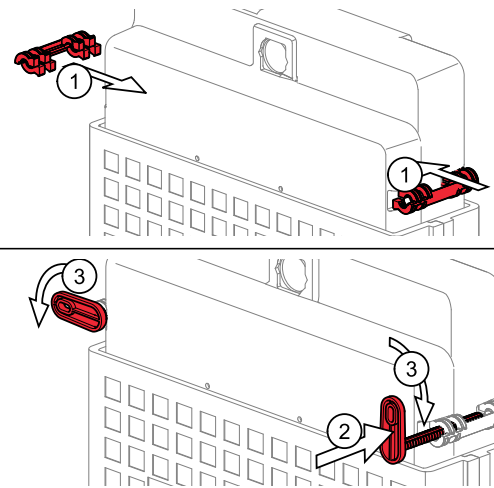

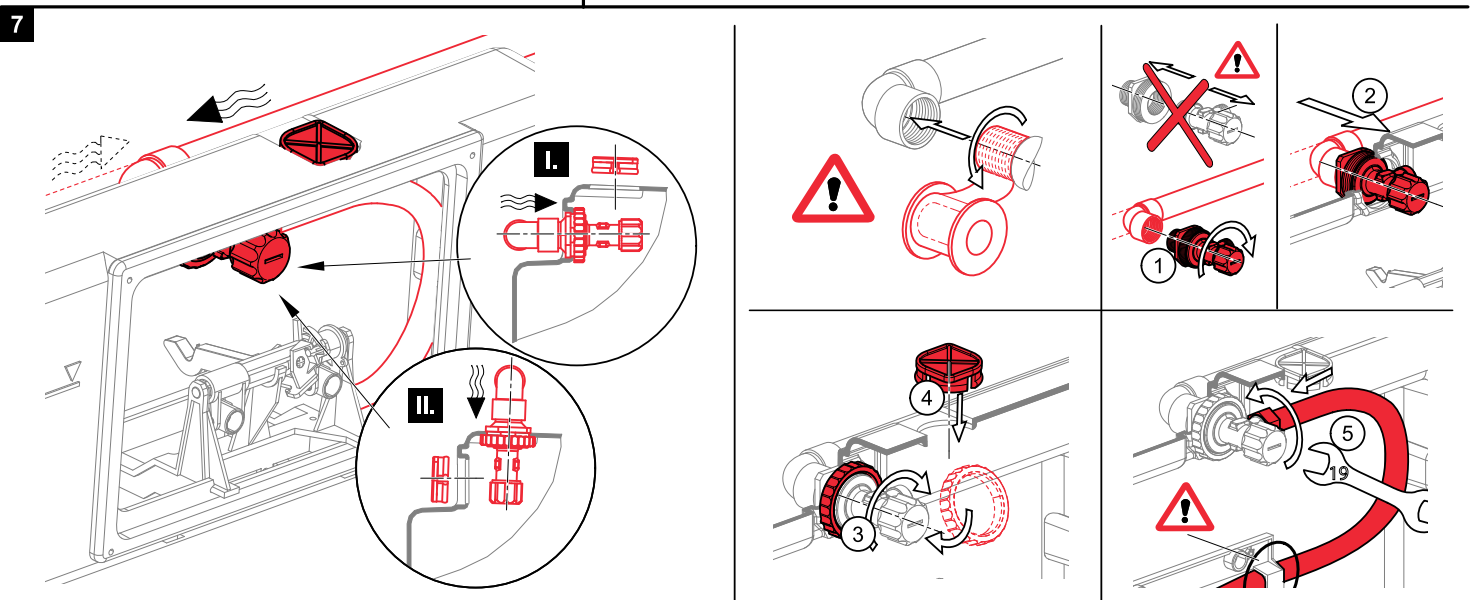
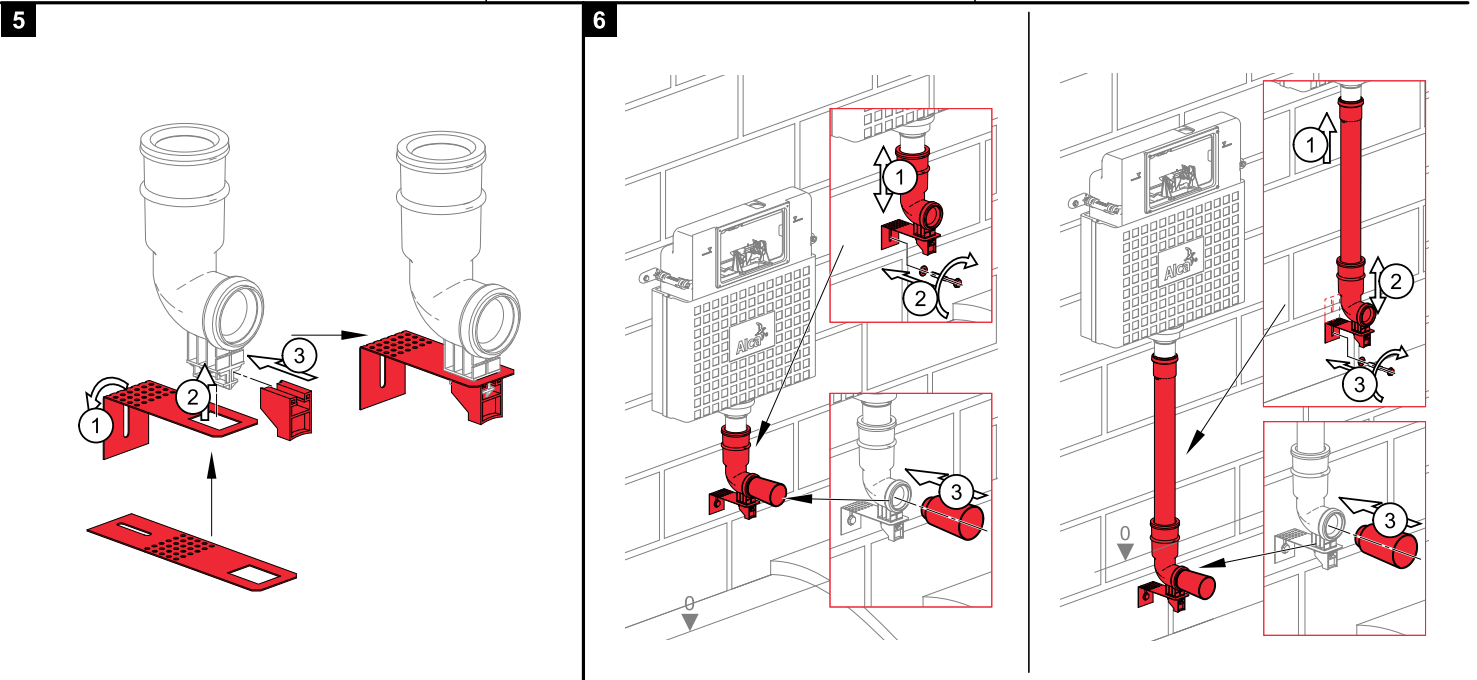
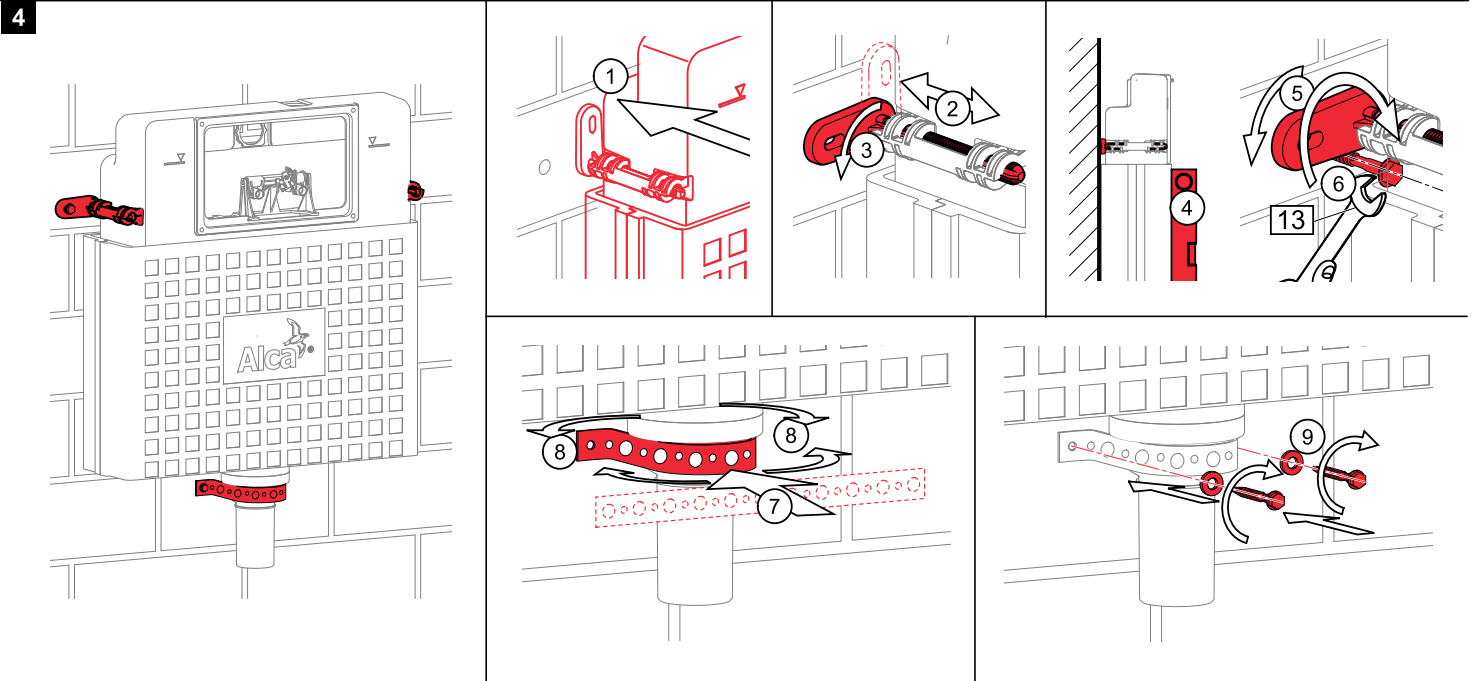

8

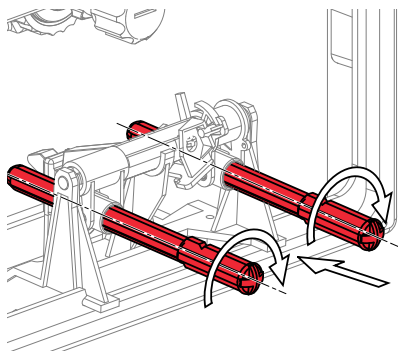

9

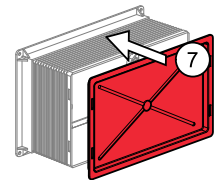
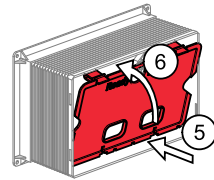
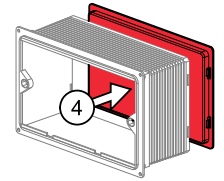
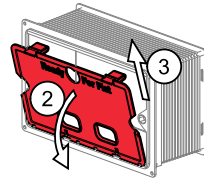
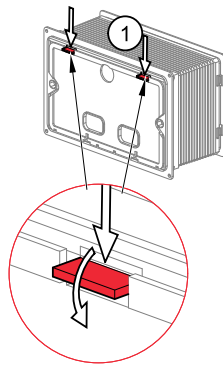

10

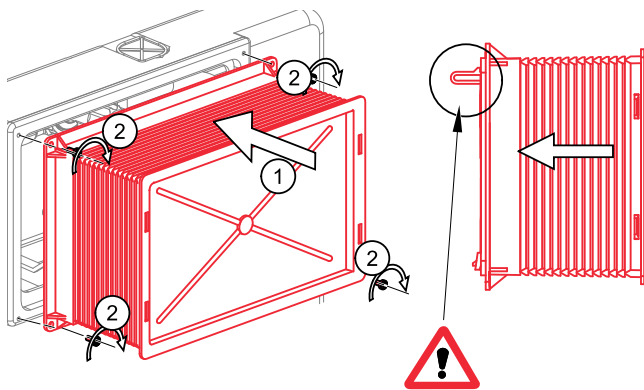

11

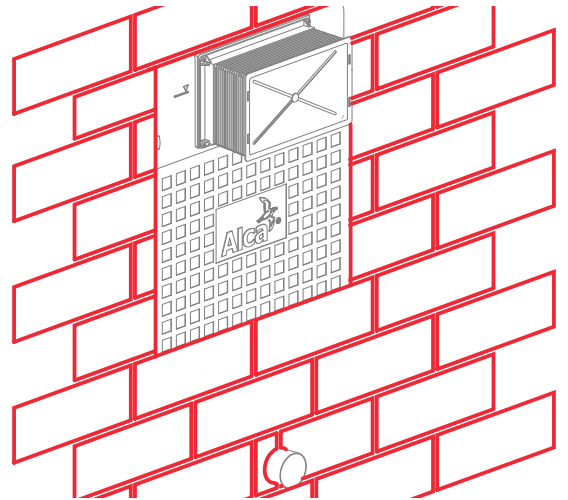

12

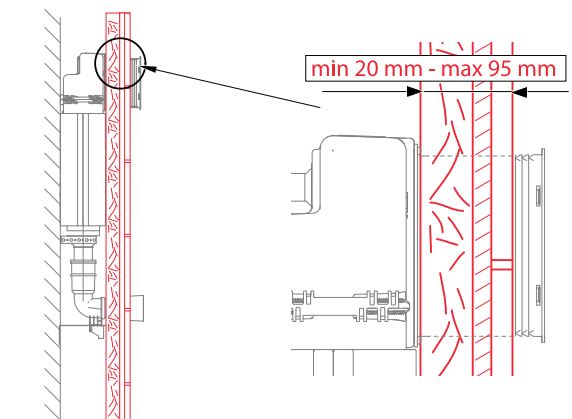
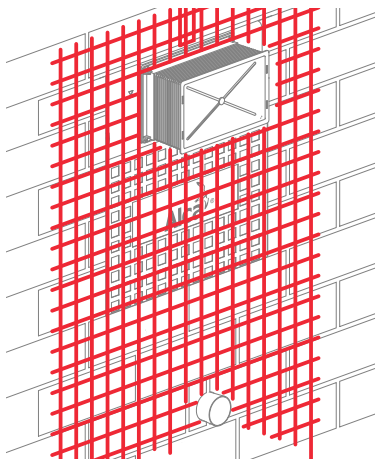

13

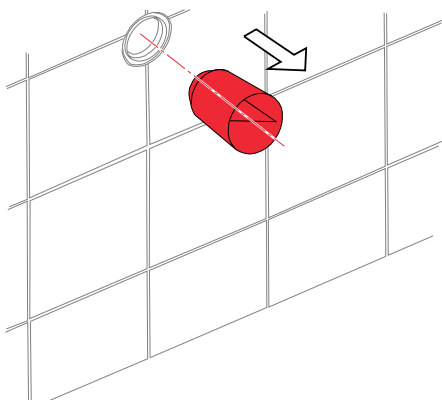

14

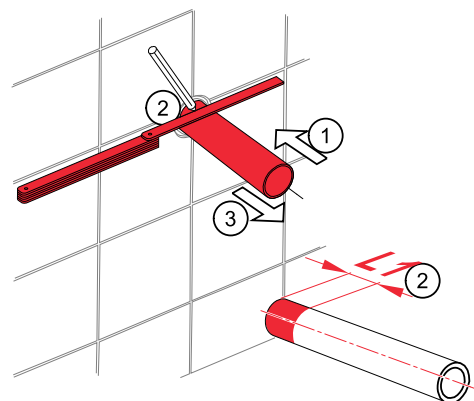

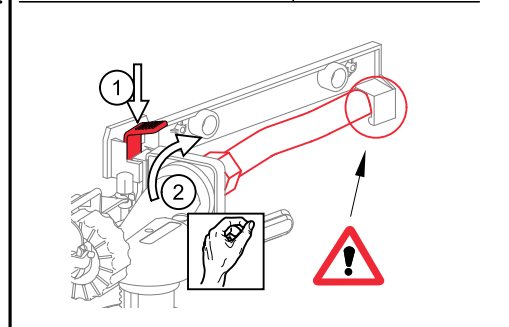
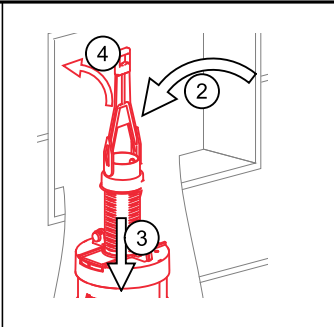
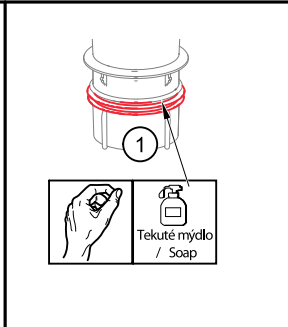
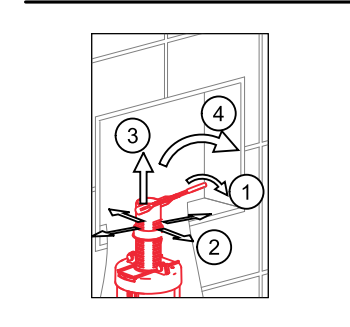
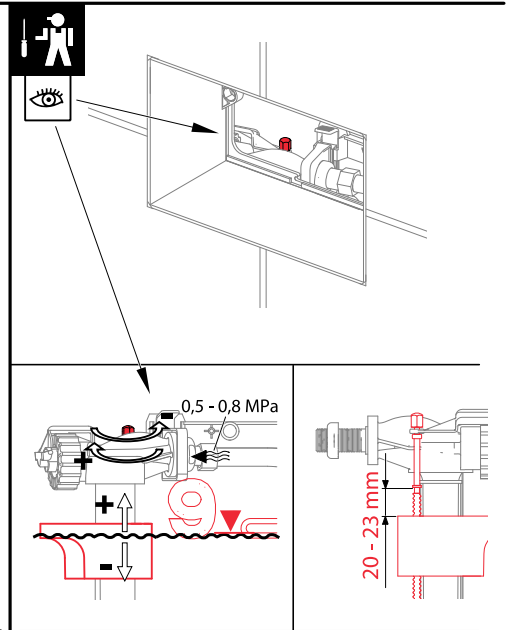
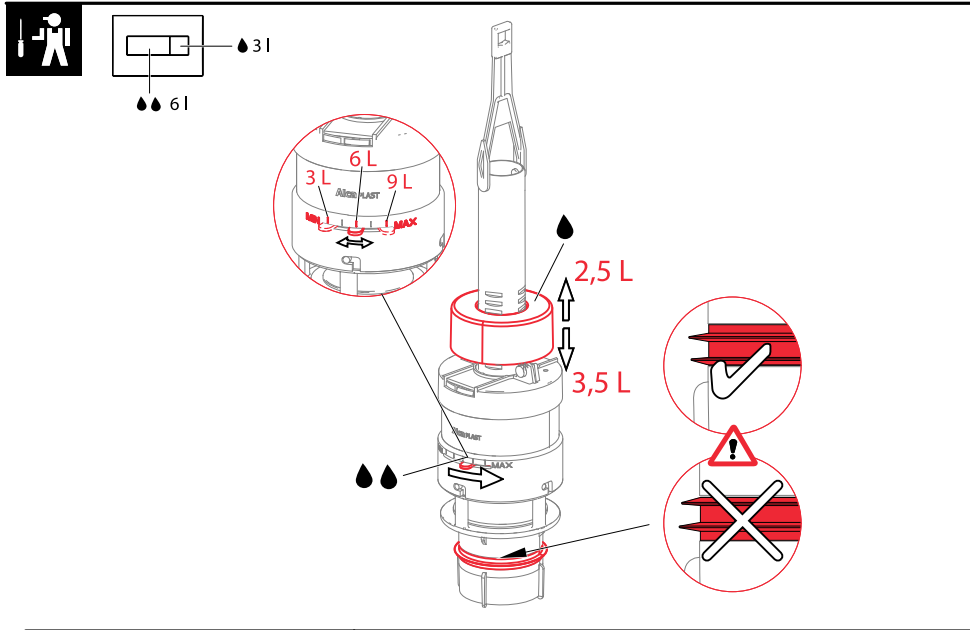
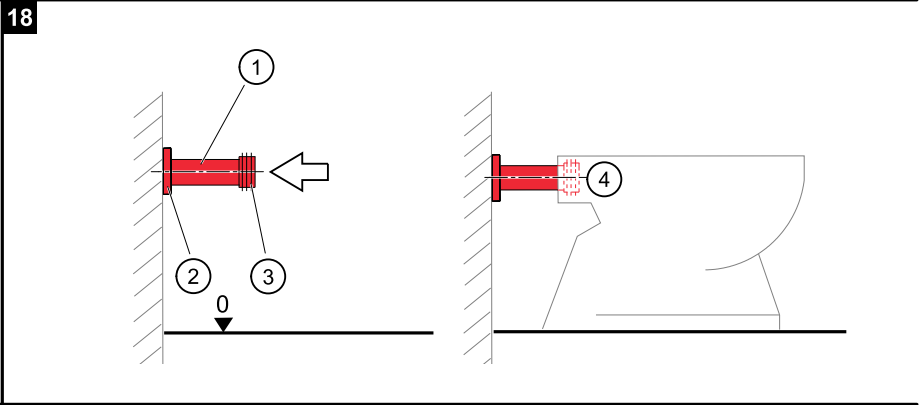
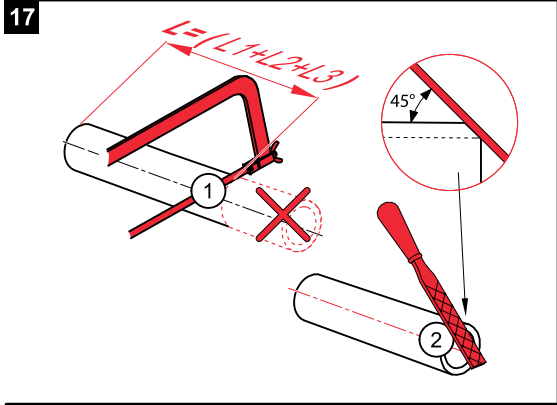
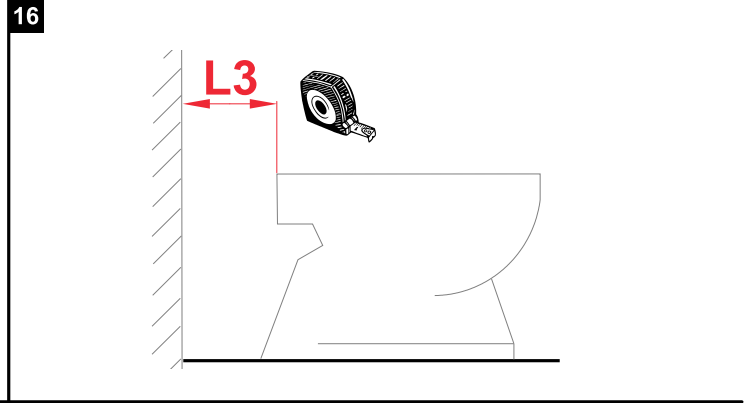
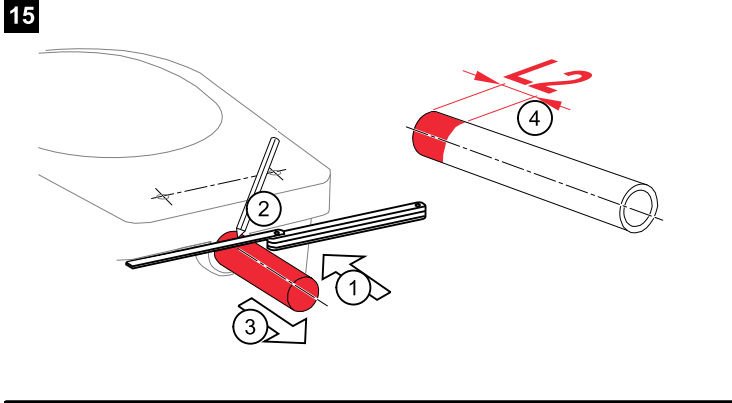

Alca plast, s. r. o.
 Bratislavská 2846, 690 02 Břeclav, Česká republika
 Tel.: +420 519 821 117 – prodej ČR
 Tel.: +420 519 821 041 – export, Fax: +420 519 821 083
 e-mail: alcaplast@alcaplast.cz, www.alcaplast.cz